

TABELA		
DESCRICOÃO	QUANT.	
1 POSTES EXISTENTES	26	
2 POSTES NOVOS	4	
3 LAJOTA DE CONCRETO 6 cm	1299,53 M ²	
4 GUIA PRÉ MOLDADA	688,34 M	

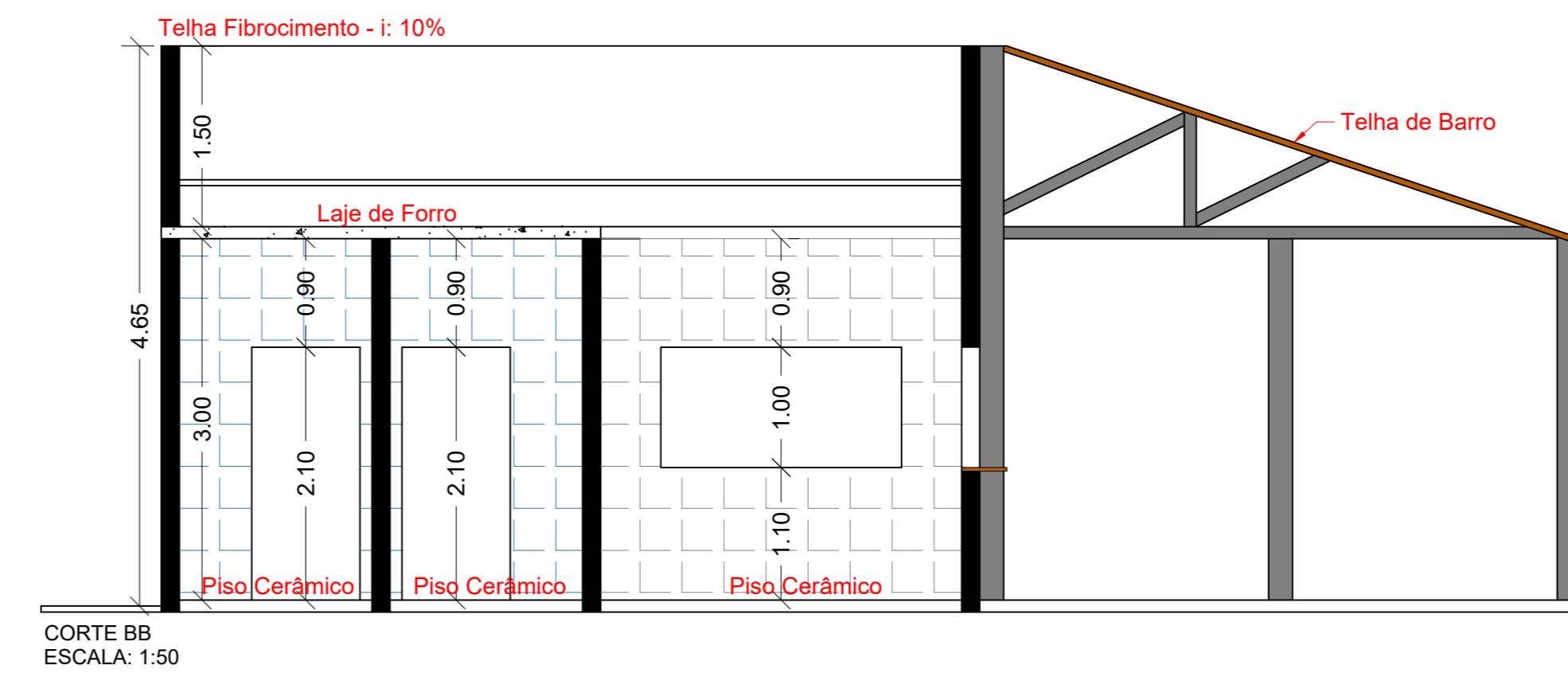

PROJETO DETALHES FL 01/01
 OBRA: REVITALIZAÇÃO E REFORMA DO LAGO MUNICIPAL

LOCAL: RUA IRACEMA, LAGO MUNICIPAL
 ALVINLÂNDIA - SP
 PROP.: Prefeitura Municipal de Alvinlândia

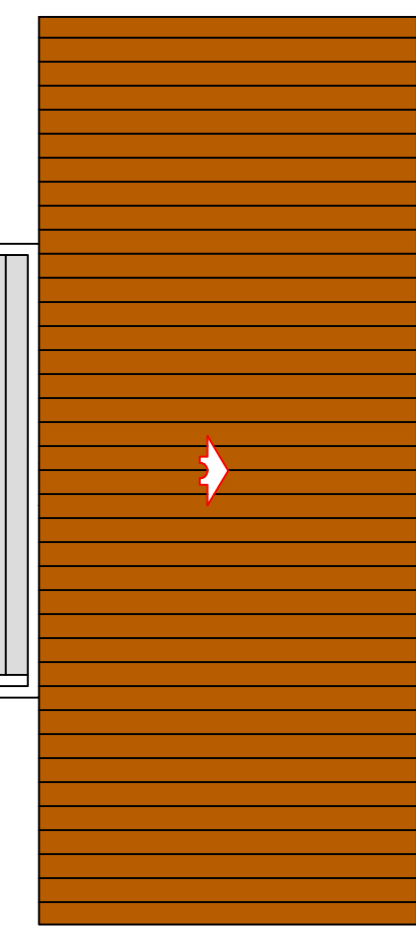
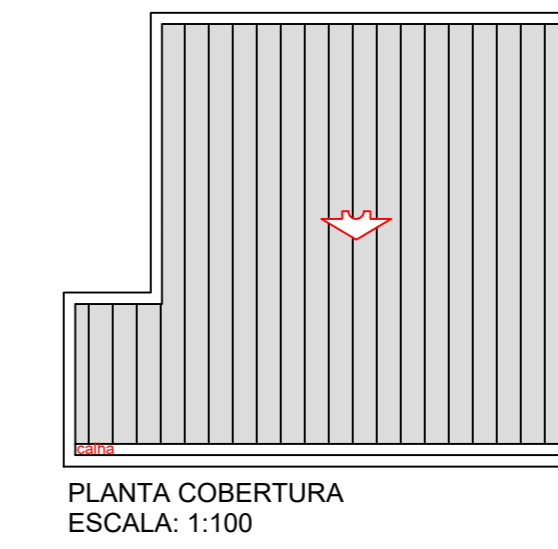
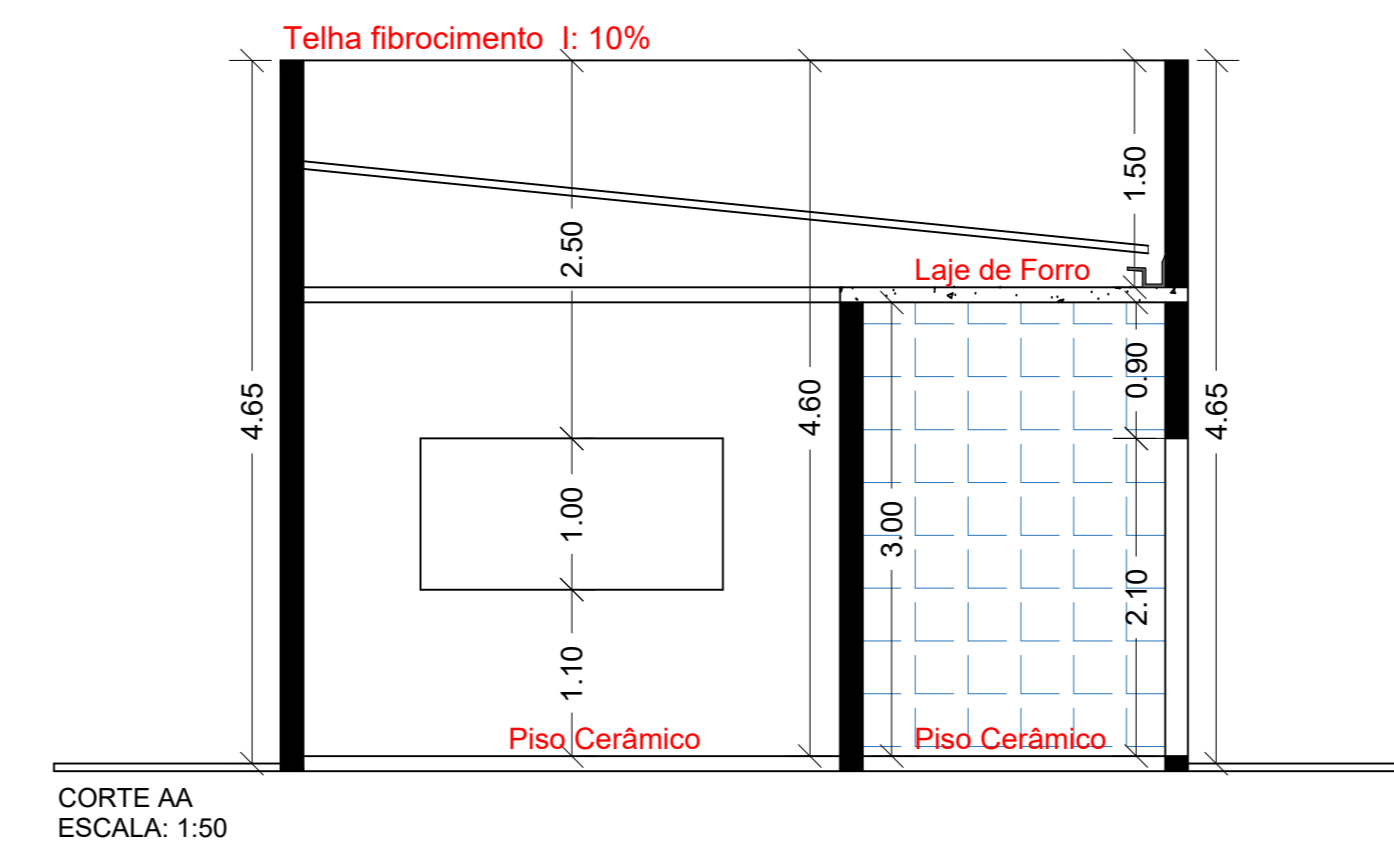
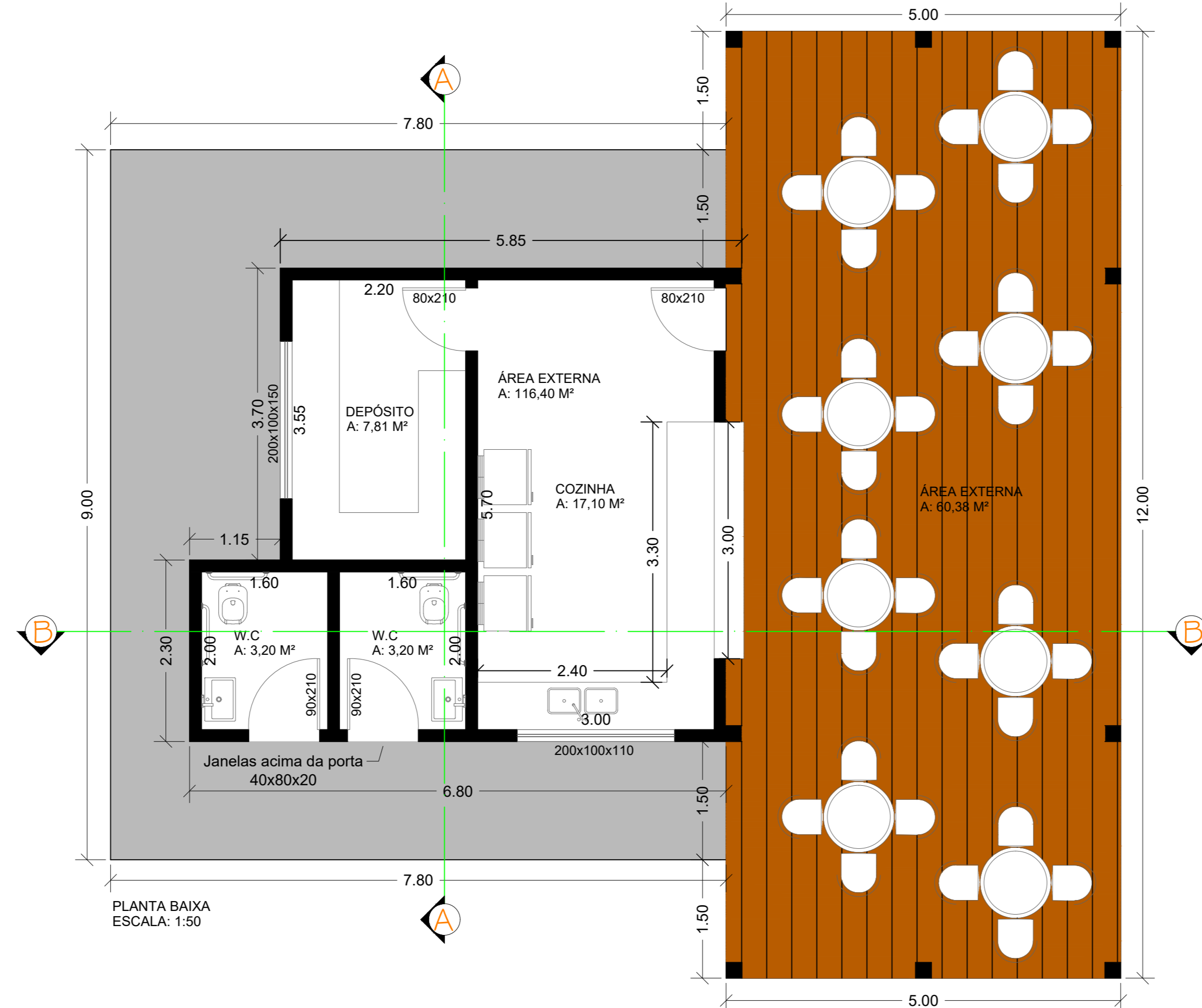
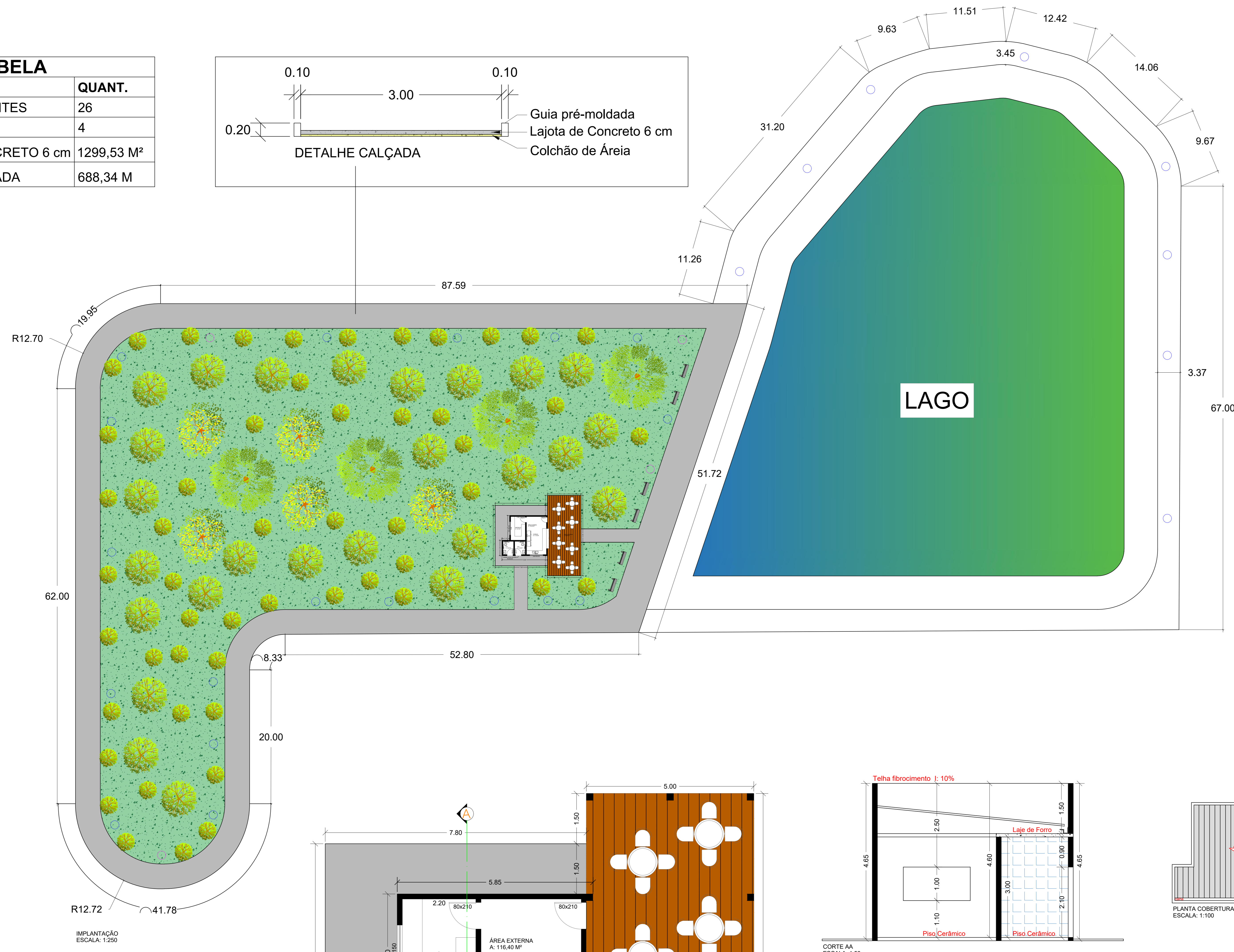
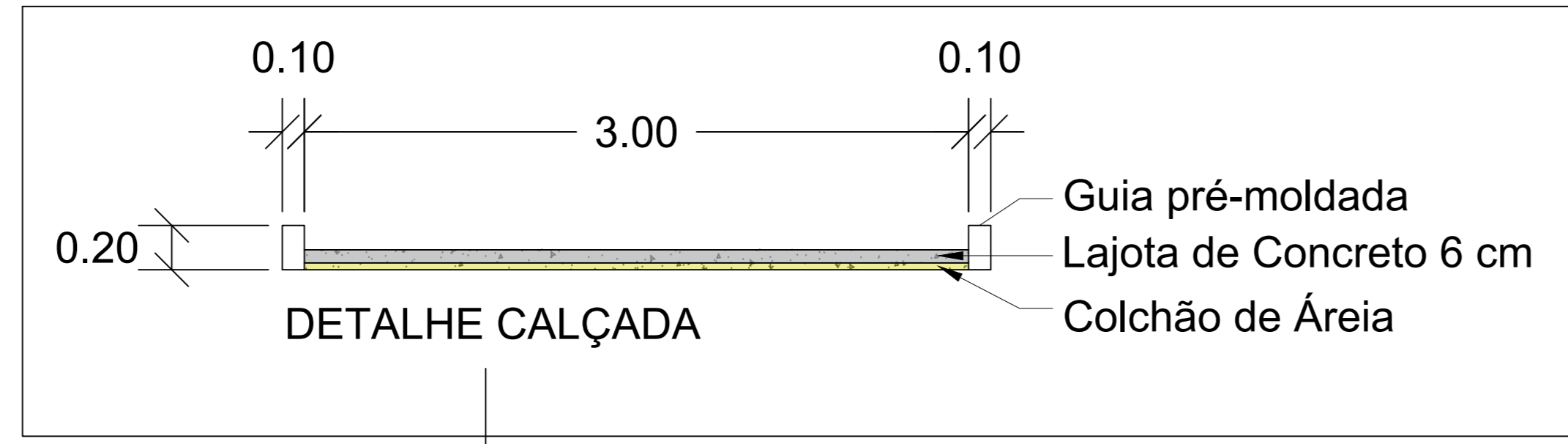

ÁREAS:
 DOS BANHEIROS E BAR 96,55M²
 DE PISO 1299,53M²

DECLARAÇÃO DE APROVAÇÃO DO PROJETO PELA PREFEITURA NÃO SE LIGA AO RECONHECIMENTO DO DIREITO DE PROPRIEDADE DO TERREIRO.
 PROP.: Prefeitura Municipal de Alvinlândia
 CNPJ: 44.576.415/0001-91
 AUTOR DO PROJ. (RESP. TÉCNICO)
 Renaldo Filho
 Rua Rui Barbosa, 1079 - Centro
 Alvinlândia - SP - CEP: 13600-000
 E-mail: renaldofilho@ig.com.br